Key Management

CS461/ECE422

Fall 2007

Reading

- Chapter 2.8 in Computer Security
- Chapter 7.3 in Computer Security, PKI
- Handbook of Applied Cryptography
<http://www.cacr.math.uwaterloo.ca/hac/>
 - Section 11.3.2 attack on RSA signature
 - Section 13.8.3 Key Escrow
- Chapter 10 in Computer Security: Art and Science

Key Management Motivation

- Cryptographic security depends on keys
 - Size
 - Generation
 - Retrieval and Storage
- Example
 - House security system no good if key or code is under the mat

Overview

- Key Generation
- Key Exchange and management
 - Classical (symmetric)
 - Public/private
- Digital Signatures
- Key Storage

Notation

- $X \rightarrow Y : \{ Z \parallel W \} k_{X,Y}$
 - X sends Y the message produced by concatenating Z and W encrypted by key $k_{X,Y}$, which is shared by users X and Y
- $A \rightarrow T : \{ Z \} k_A \parallel \{ W \} k_{A,T}$
 - A sends T a message consisting of the concatenation of Z encrypted using k_A , A 's key, and W encrypted using $k_{A,T}$, the key shared by A and T
- r_1, r_2 nonces (nonrepeating random numbers)

Session and Interchange Keys

- Long lived Interchange Keys only exist to boot strap
- Short lived session keys used for bulk encryption

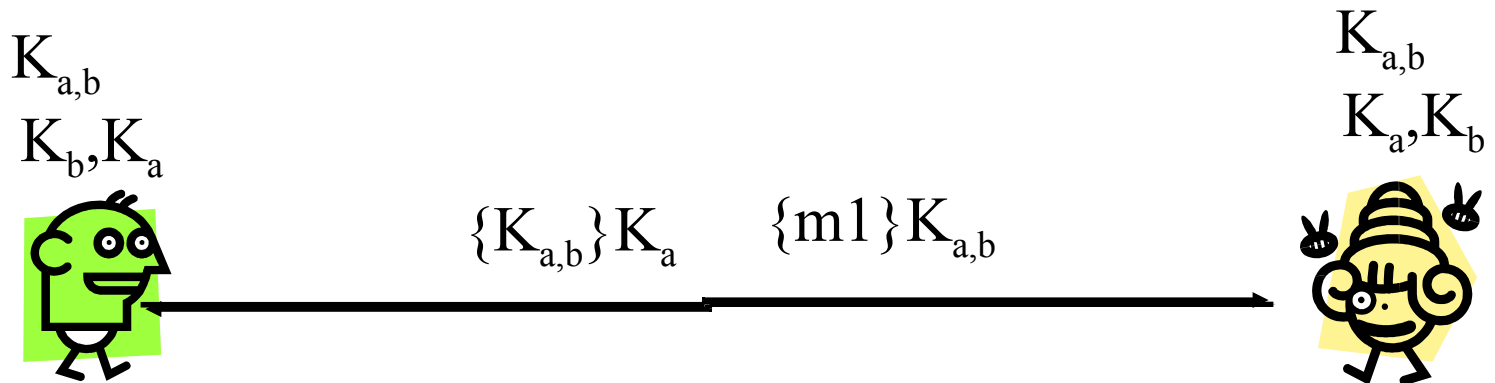

Session and Interchange Keys

- Alice wants to send a message m to Bob
 - Assume public key encryption
 - Alice generates a random cryptographic key k_s and uses it to encrypt m
 - To be used for this message *only*
 - Called a *session key*
 - She encrypts k_s with Bob's public key k_B
 - k_B encrypts all session keys Alice uses to communicate with Bob
 - Called an *interchange key*
 - Alice sends $\{ m \} k_s || \{ k_s \} k_B$

Benefits

- Limits amount of traffic encrypt with single key
 - Standard practice, to decrease the amount of traffic an attacker can obtain
- Prevents some attacks
 - Example: Alice will send Bob message that is either “BUY” or “SELL”. Eve computes possible ciphertexts $\{ \text{“BUY”} \} k_B$ and $\{ \text{“SELL”} \} k_B$. Eve intercepts encrypted message, compares, and gets plaintext at once

Key Generation

- Goal: generate keys that are difficult to guess
- Problem statement: given a set of K potential keys, choose one randomly
 - Equivalent to selecting a random number between 0 and $K-1$ inclusive
- Why is this hard: generating random numbers
 - Actually, numbers are usually *pseudo-random*, that is, generated by an algorithm

What is “Random”?

- *Sequence of cryptographically random numbers*: a sequence of numbers n_1, n_2, \dots such that for any integer $k > 0$, an observer cannot predict n_k even if all of n_1, \dots, n_{k-1} are known
 - Best: physical source of randomness
 - Random pulses
 - Electromagnetic phenomena
 - Characteristics of computing environment such as disk latency
 - Ambient background noise

What is “Pseudorandom”?

- *Sequence of cryptographically pseudorandom numbers*: sequence of numbers intended to simulate a sequence of cryptographically random numbers but generated by an algorithm
 - Very difficult to do this well
 - Linear congruential generators [$n_k = (an_{k-1} + b) \bmod n$] broken
 - Polynomial congruential generators [$n_k = (a_j n_{k-1}^j + \dots + a_1 n_{k-1} + a_0) \bmod n$] broken too
 - Here, “broken” means next number in sequence can be determined

Best Pseudorandom Numbers

- *Strong mixing function*: function of 2 or more inputs with each bit of output depending on some nonlinear function of all input bits

- Examples: DES, MD5, SHA-1, avalanche effect
- Use on UNIX-based systems:

```
(date; ps gaux) | md5
```

where “ps gaux” lists all information about all processes on system

Separate Channel

- Ideally you have separate secure channel for exchanging keys
 - Direct secret sharing grows at N^2

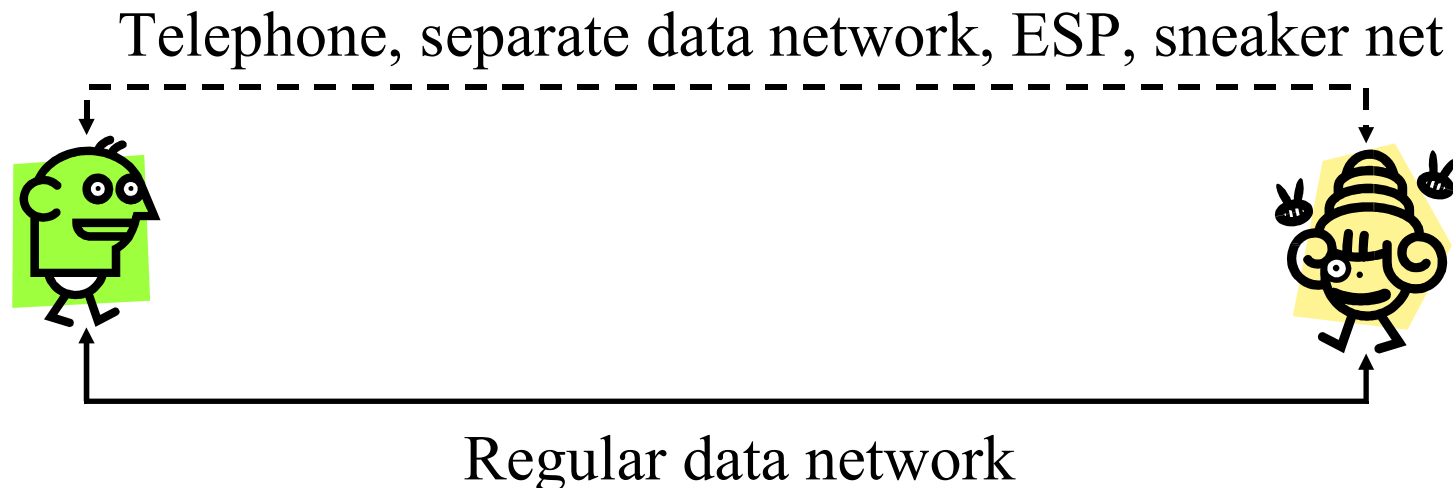

Key Exchange Algorithms

- Goal: Alice, Bob get shared key
 - All cryptosystems, protocols publicly known
 - Only secret data is the keys
 - Anything transmitted is assumed known to attacker
 - Key cannot be sent in clear as attacker can listen in
 - Options
 - Key can be sent encrypted, or derived from exchanged data plus data not known to an eavesdropper (Diffie-Hellman)
 - Alice, Bob may trust third party

Shared Channel

- Generally separate channel is not practical
 - No trustworthy separate channel
 - Want to scale linearly with additional users

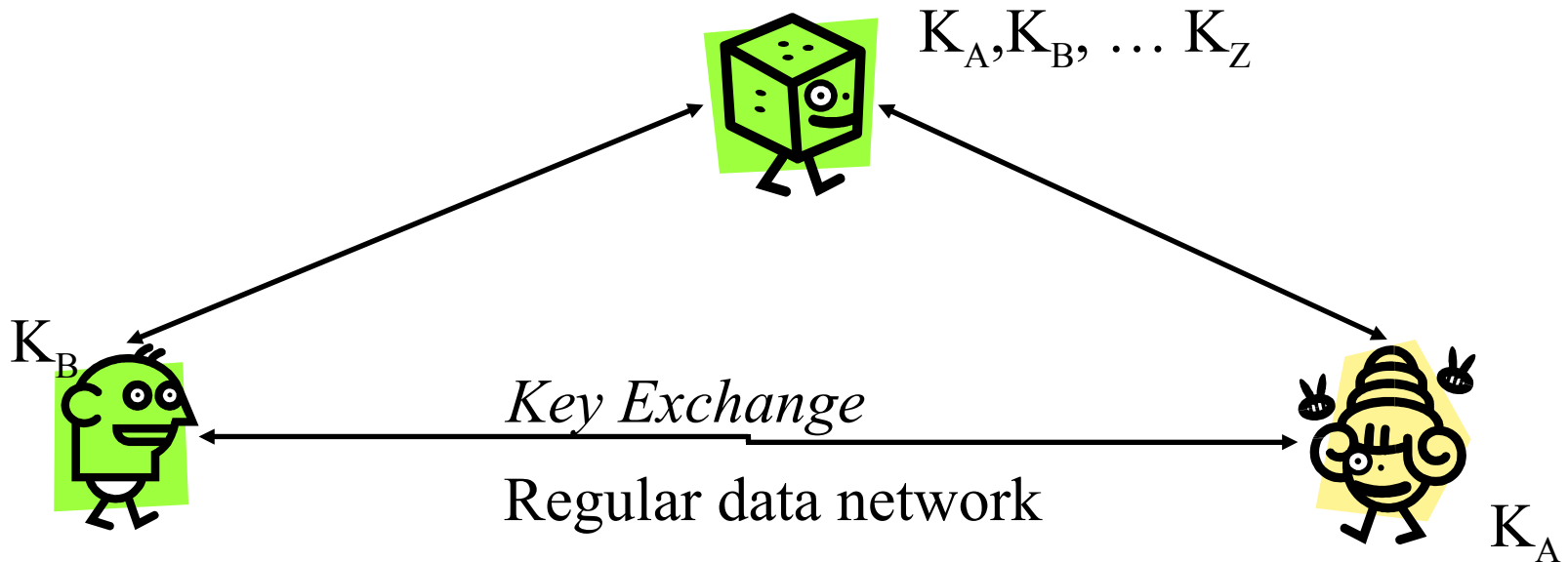

Classical Key Exchange

- Bootstrap problem: how do Alice, Bob begin?
 - Alice can't send it to Bob in the clear!
- Assume trusted third party, Cathy
 - Alice and Cathy share secret key k_A
 - Bob and Cathy share secret key k_B
- Use this to exchange shared key k_s

Simple Protocol

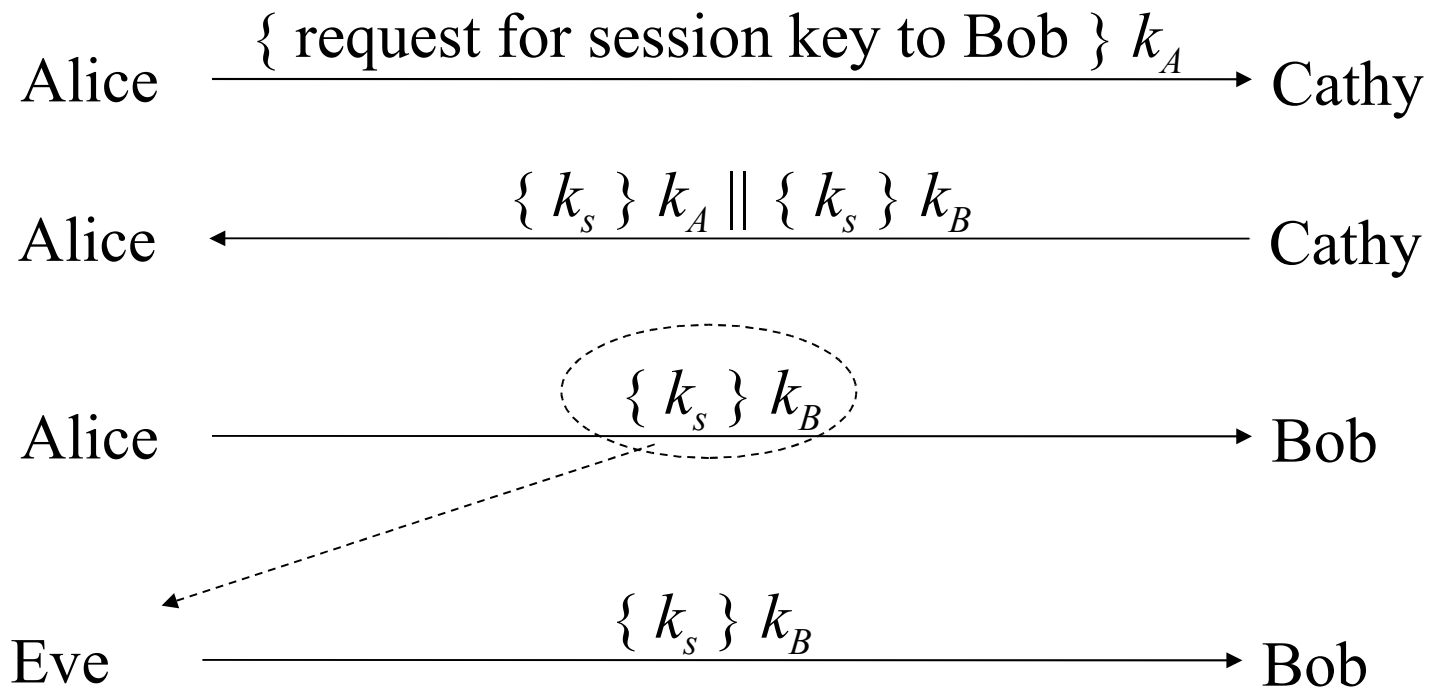

Problems

- How does Bob know he is talking to Alice?
 - Replay attack: Eve records message from Alice to Bob, later replays it; Bob may think he's talking to Alice, but he isn't
 - Session key reuse: Eve replays message from Alice to Bob, so Bob re-uses session key
- Protocols must provide authentication and defense against replay

Needham-Schroeder

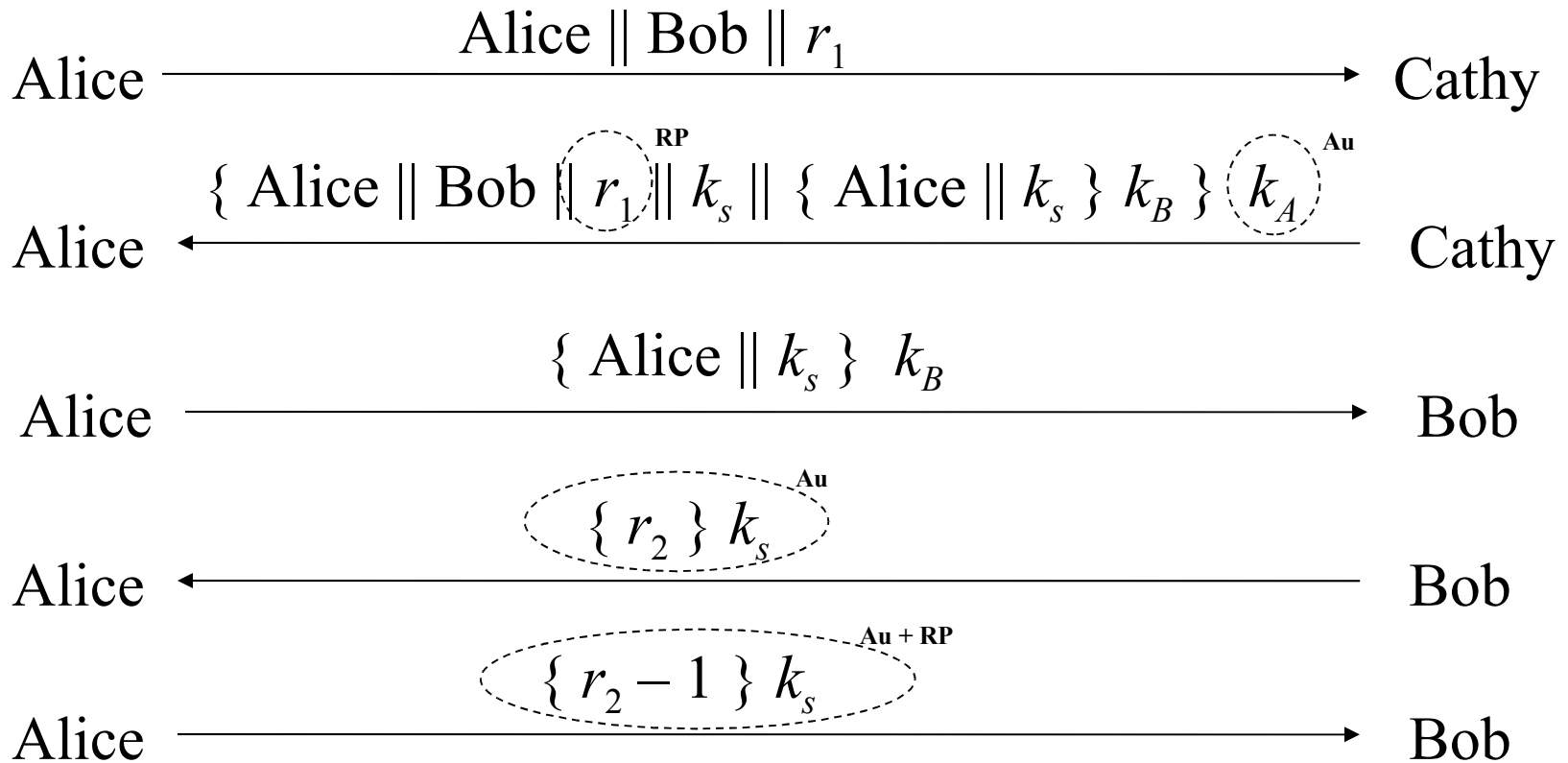

Argument: Alice talking to Bob

- Second message
 - Encrypted using key only she, Cathy knows
 - So Cathy encrypted it
 - Response to first message
 - As r_1 in it matches r_1 in first message
- Third message
 - Alice knows only Bob can read it
 - As only Bob can derive session key from message
 - Any messages encrypted with that key are from Bob

Argument: Bob talking to Alice

- Third message
 - Encrypted using key only he, Cathy know
 - So Cathy encrypted it
 - Names Alice, session key
 - Cathy provided session key, says Alice is other party
- Fourth message
 - Uses session key to determine if it is replay from Eve
 - If not, Alice will respond correctly in fifth message
 - If so, Eve can't decrypt r_2 and so can't respond, or responds incorrectly

Denning-Sacco Modification

- Needham-Schroeder Assumption: all keys are secret
- Question: suppose Eve can obtain session key. How does that affect protocol?
 - In what follows, Eve knows k_s

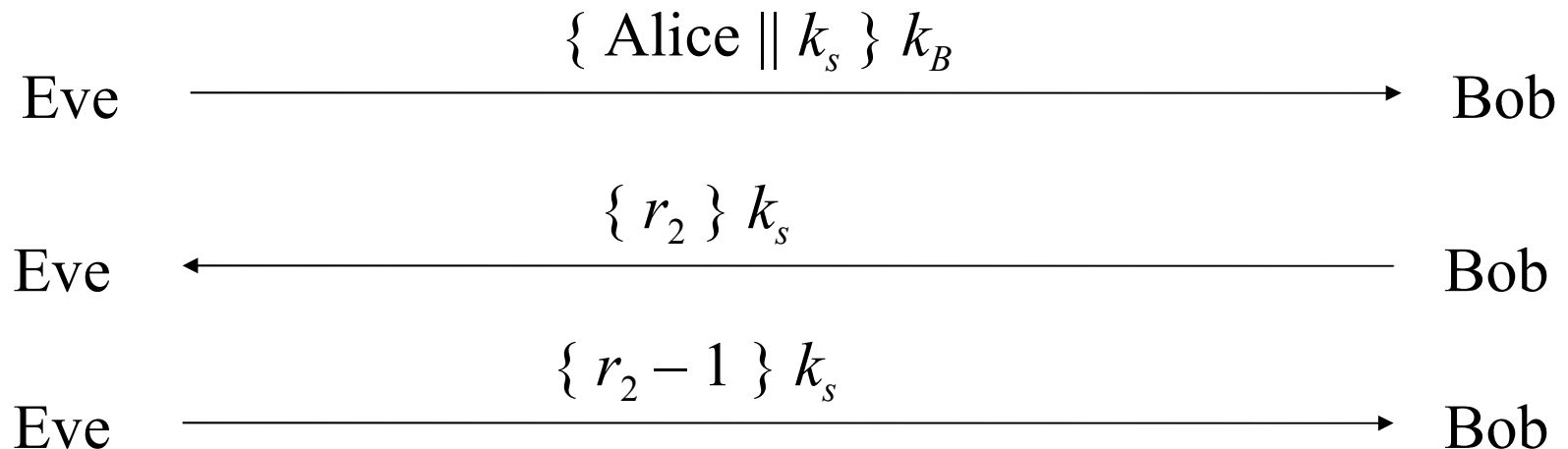

Solution

- In protocol above, Eve impersonates Alice
- Problem: replay in third step
 - First in previous slide
- Solution: use time stamp T to detect replay
- Weakness: if clocks not synchronized, may either reject valid messages or accept replays
 - Parties with either slow or fast clocks vulnerable to replay

Needham-Schroeder with Denning-Sacco Modification

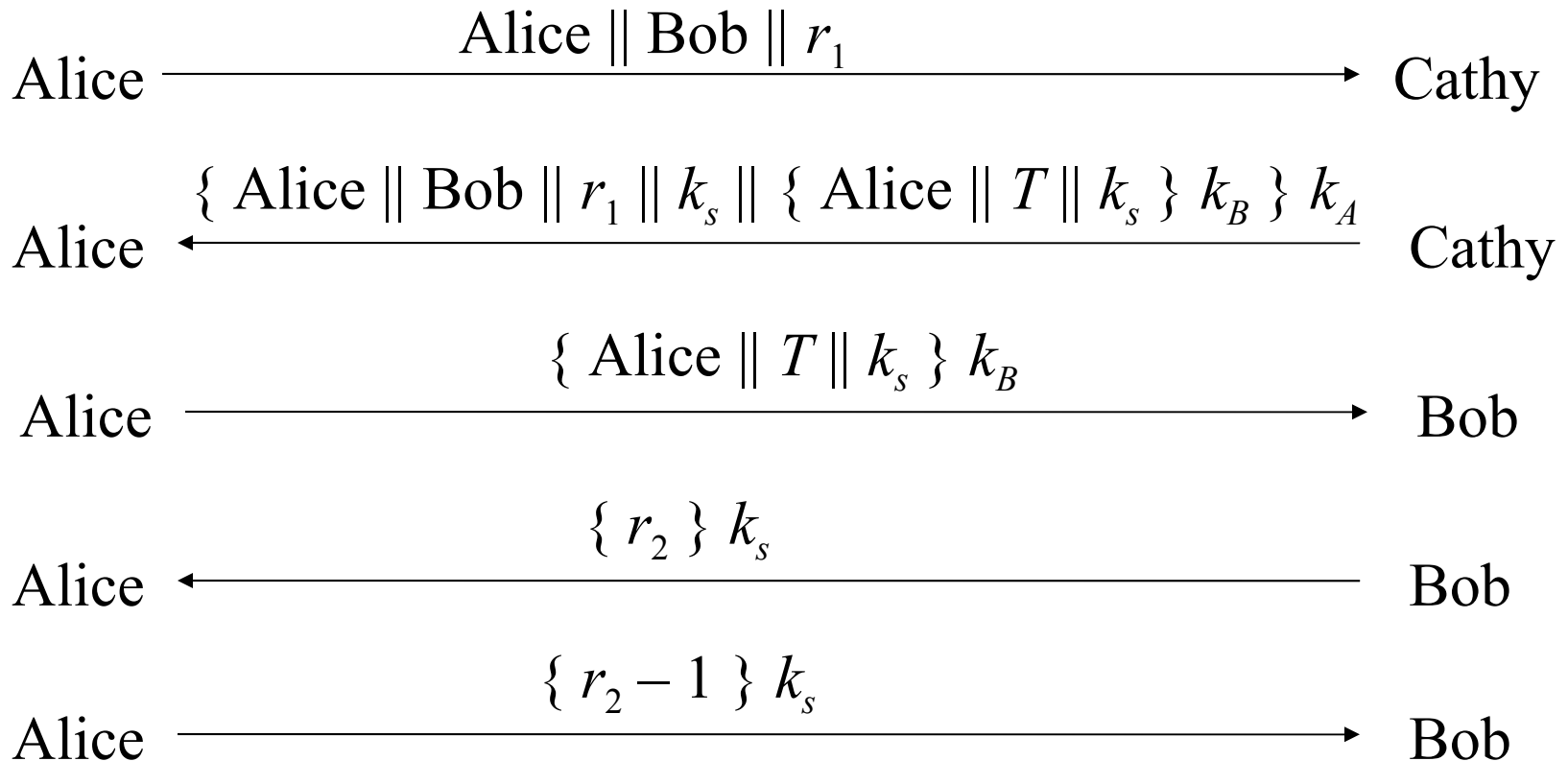

Otway-Rees Protocol

- Corrects problem
 - That is, Eve replaying the third message in the protocol
- Does not use timestamps
 - Not vulnerable to the problems that Denning-Sacco modification has

The Protocol

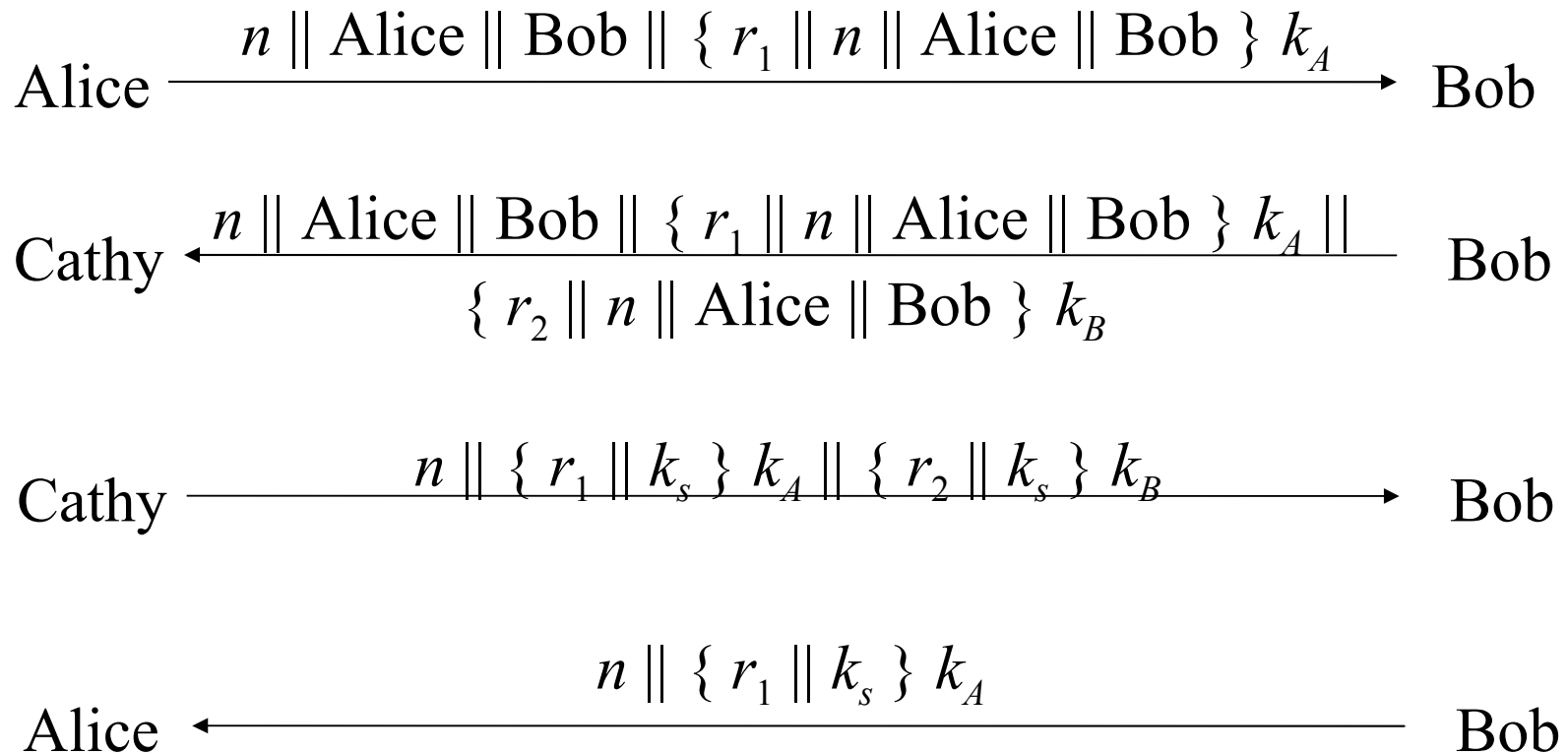

Argument: Alice talking to Bob

- Fourth message
 - If n matches first message, Alice knows it is part of this protocol exchange
 - Cathy generated k_s because only she, Alice know k_A
 - Encrypted part belongs to exchange as r_1 matches r_1 in encrypted part of first message

Argument: Bob talking to Alice

- Third message
 - If n matches second message, Bob knows it is part of this protocol exchange
 - Cathy generated k_s because only she, Bob know k_B
 - Encrypted part belongs to exchange as r_2 matches r_2 in encrypted part of second message

Replay Attack

- Eve acquires old k_s , message in third step
 - $n \parallel \{ r_1 \parallel k_s \} k_A \parallel \{ r_2 \parallel k_s \} k_B$
- Eve forwards appropriate part to Alice
 - Nonce r_1 matches nothing, so is rejected

Network Authentication with Kerberos

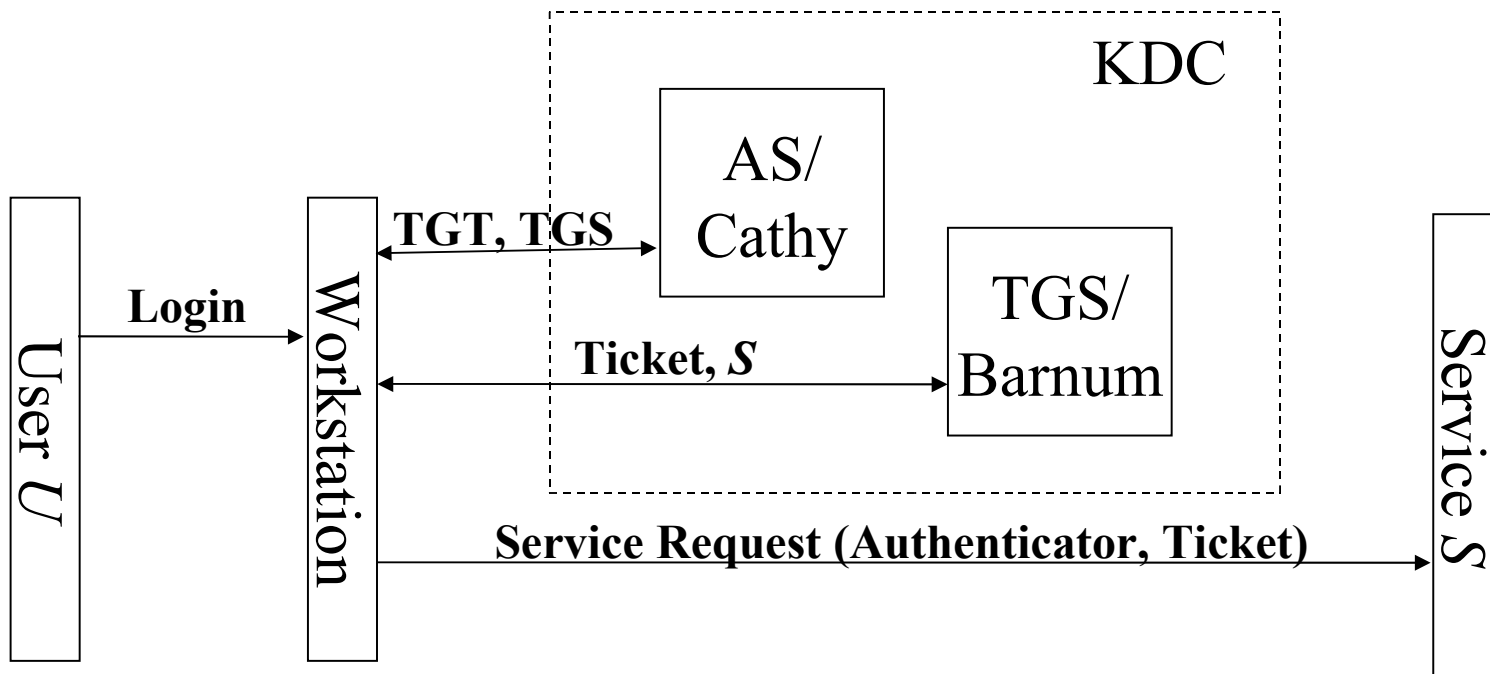

Legend: AS = Authentication Server; TGS = Ticket Granting Server
KDC = Key Distribution Center; TGT = Ticket Granting Ticket;

Kerberos

- Authentication system
 - Based on Needham-Schroeder with Denning-Sacco modification
 - Central server plays role of trusted third party (“Cathy”)
- Ticket
 - Issuer vouches for identity of requester of service
- Authenticator
 - Identifies sender
- Two Competing Versions: 4 and 5
 - Version 4 discussed here

Idea

- User u authenticates to Kerberos AS
 - Obtains ticket (TGT) $T_{u,TGS}$ for ticket granting service (TGS)
- User u wants to use service s :
 - User sends authenticator A_u , ticket $T_{u,TGS}$ to TGS asking for ticket for service
 - TGS sends ticket $T_{u,s}$ to user
 - User sends A_u , $T_{u,s}$ to server as request to use s
- Details follow

Ticket

- Credential saying issuer has identified ticket requester
- Example ticket issued to user u for TGS

$$T_{u,\text{TGS}} = \text{TGS} \parallel \{ u \parallel u\text{'s address} \parallel \text{valid time} \parallel k_{u,\text{TGS}} \} k_{\text{AS},\text{TGS}}$$

where:

- $k_{u,\text{TGS}}$ is session key for user and TGS
- $k_{\text{AS},\text{TGS}}$ is long-term key shared between AS and TGS
- Valid time is interval for which ticket valid; e.g., a day
- u 's address may be IP address or something else
 - Note: more fields, but not relevant here

Ticket

- Example ticket issued to user u for service s

$$T_{u,s} = s \parallel \{ u \parallel u\text{'s address} \parallel \text{valid time} \parallel k_{u,s} \} k_s$$

where:

- $k_{u,s}$ is session key for user and service
- k_s is long-term key shared between TGS and S
- Valid time is interval for which ticket valid; e.g., hours/days
- u 's address may be IP address or something else
 - Note: more fields, but not relevant here

Authenticator

- Credential containing identity of sender of ticket
 - Used to confirm sender is entity to which ticket was issued
- Example: authenticator user u generates for service s

$$A_{u,s} = \{ u \parallel \text{generation time} \} k_{u,s}$$

where:

- Generation time is when authenticator generated
 - Note: more fields, not relevant here

Protocol

- * Initially, user u registers with KDC and establishes a password
- used to derive long-term key k_u
- * User U logs into workstation (WS) using password

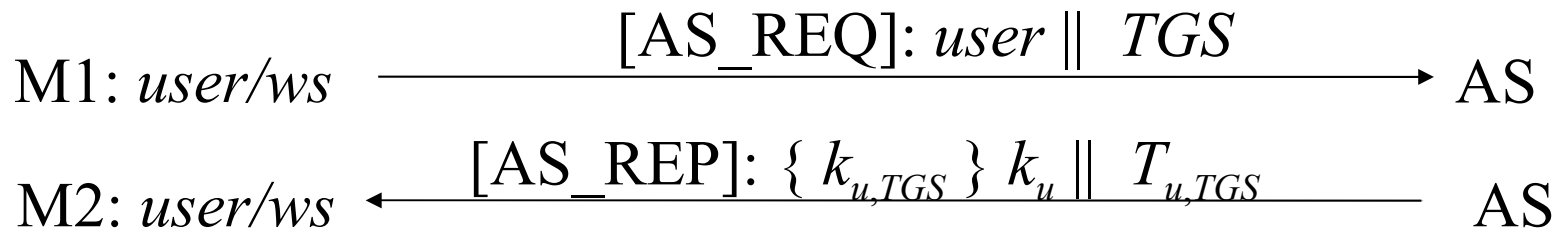

- * WS decrypts session key $k_{u,TGS}$ using supplied password

Protocol

M3: *user/ws* $\xrightarrow{[\text{TGS_REQ}]: \textit{service} \parallel A_{u,\text{TGS}} \parallel T_{u,\text{TGS}}}$ TGS

* TGS decrypts ticket using long-term key $k_{AS,\text{TGS}}$

M4: *user/ws* $\xleftarrow{[\text{TGS_REP}]: \textit{user} \parallel \{k_{u,s}\} k_{u,\text{TGS}} \parallel T_{u,s}}$ TGS

M5: *user/ws* $\xrightarrow{[\text{AP_REQ}]: A_{u,s} \parallel T_{u,s}}$ *service*

* Service decrypts ticket using long-term key $k_{\text{TGS},s}$

M6: *user/ws* $\xleftarrow{[\text{AP_REP}]: \{t+1\} k_{u,s}}$ *service*

Summary of Messages

- First two messages get user ticket to use TGS
 - User u can obtain session key only if u knows key shared with AS
- Next four messages show how u gets and uses ticket for service s
 - Service s validates request by checking sender (using $A_{u,s}$) is same as entity ticket issued to
 - Step 6 optional; used when u requests confirmation

Problems

- Relies on synchronized clocks
 - Typical clock skew allowed is 5 minutes
 - If not synchronized and old tickets, authenticators not cached, replay is possible
- Tickets have some fixed fields
 - Dictionary attacks possible
 - Kerberos 4 session keys weak (had much less than 56 bits of randomness); researchers at Purdue found them from tickets in minutes

Public Key Key Exchange

- Here interchange keys known
 - e_A, e_B Alice and Bob's public keys known to all
 - d_A, d_B Alice and Bob's private keys known only to owner
- Simple protocol
 - k_s is desired session key

Alice $\xrightarrow{\{k_s\} e_B}$ Bob

Problem and Solution

- Vulnerable to forgery or replay
 - Because e_B known to anyone, Bob has no assurance that Alice sent message
- Simple fix uses Alice's private key
 - k_s is desired session key

Alice $\xrightarrow{\{ \{ k_s \} d_A \} e_B}$ Bob

Notes

- Can include message enciphered with k_s
- Assumes Bob has Alice's public key, and *vice versa*
 - If not, each must get it from public server
 - If keys not bound to identity of owner, attacker Eve can launch a *man-in-the-middle* attack (next slide; Cathy is public server providing public keys)
 - Solution to this (binding identity to keys) discussed later as public key infrastructure (PKI)

Man-in-the-Middle Attack

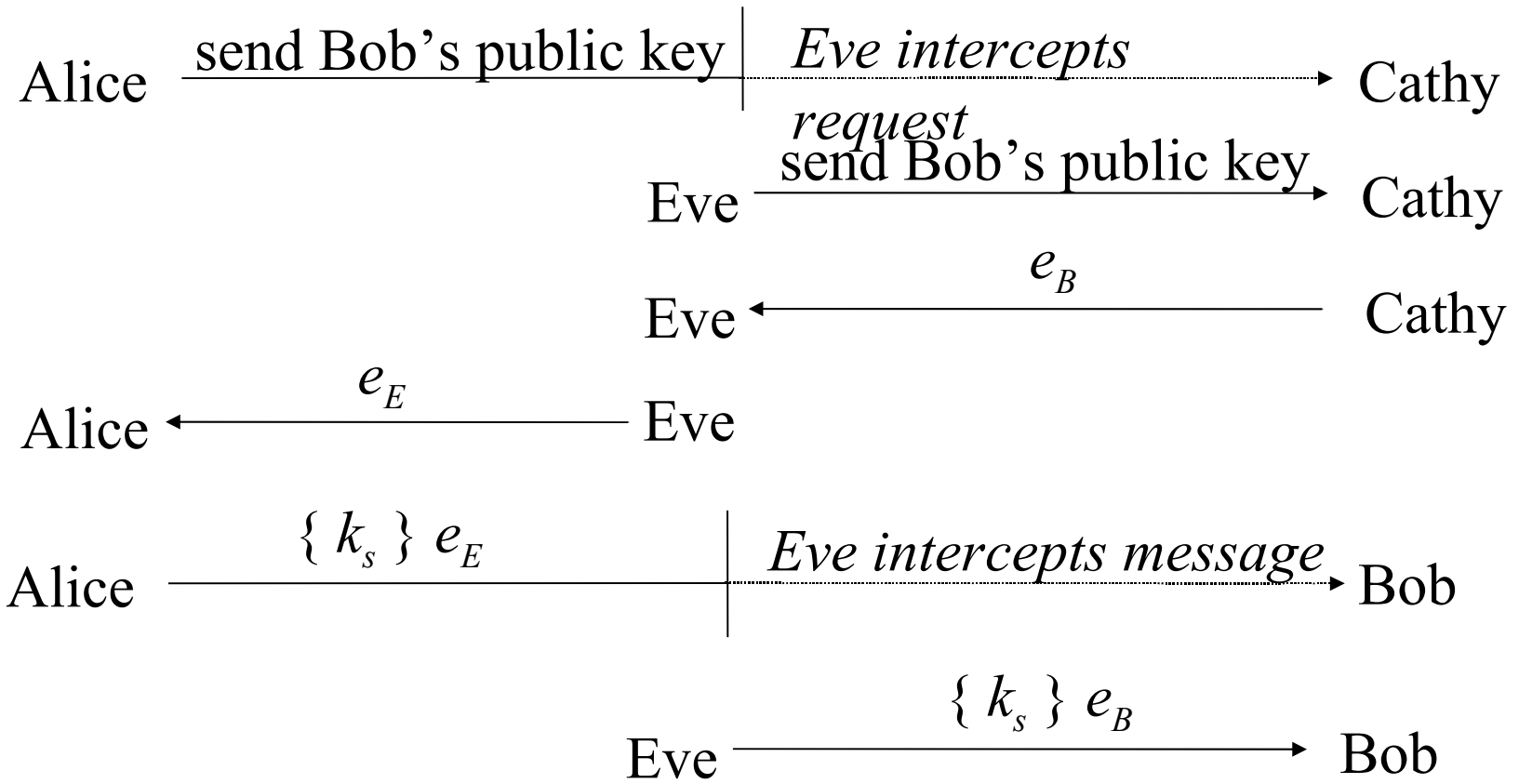

Cryptographic Key Infrastructure

- Goal: bind identity to key
- Classical: not possible as all keys are shared
 - Use protocols to agree on a shared key (see earlier)
- Public key: bind identity to public key
 - Crucial as people will use key to communicate with principal whose identity is bound to key
 - Erroneous binding means no secrecy between principals
 - Assume principal identified by an acceptable name

Certificates

- Create token (message) containing
 - Identity of principal (here, Alice)
 - Corresponding public key
 - Timestamp (when issued)
 - Other information (perhaps identity of signer)
 - Compute hash (message digest) of token

Hash encrypted by trusted authority (here, Cathy) using private key: called a “signature”

$$C_A = e_A \parallel \text{Alice} \parallel T \parallel \{h(e_A \parallel \text{Alice} \parallel T)\} d_C$$

Use

- Bob gets Alice's certificate
 - If he knows Cathy's public key, he can validate the certificate
 - Decrypt encrypted hash using Cathy's public key
 - Re-compute hash from certificate and compare
 - Check validity
 - Is the principal Alice?
 - Now Bob has Alice's public key
- Problem: Bob needs Cathy's public key to validate certificate
 - That is, secure distribution of public keys
 - Solution: Public Key Infrastructure (PKI) using trust anchors called Certificate Authorities (CAs) that issue certificates

PKI Trust Models

- **A Single Global CA**

- Unmanageable, inflexible
- There is no universally trusted organization

- **Hierarchical CAs (Tree)**

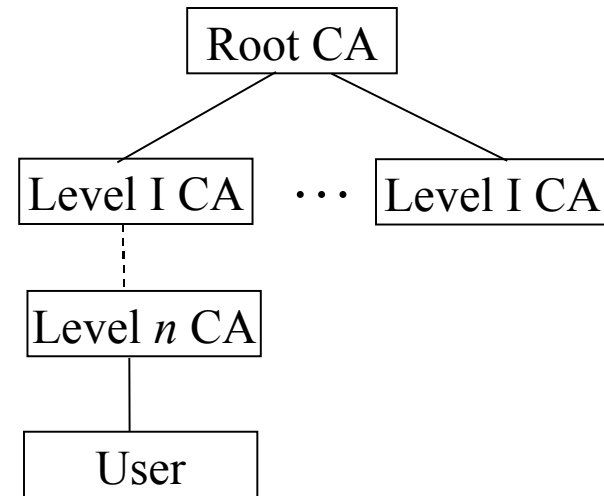

- Offloads burden on multiple CAs
- Need to verify a chain of certificates
- Still depends on a single trusted root CA

PKI Trust Models

- Hierarchical CAs with cross-certification
 - Multiple root CAs that are cross-certified
 - Cross-certification at lower levels for efficiency
- Web Model
 - Browsers come pre-configured with multiple trust anchor certificates
 - New certificates can be added
- Distributed (e.g., PGP)
 - No CA; instead, users certify each other to build a “web of trust”

X.509 Certificates

- Some certificate components in X.509v3:
 - Version
 - Serial number
 - Signature algorithm identifier: hash algorithm
 - Issuer's name; uniquely identifies issuer
 - Interval of validity
 - Subject's name; uniquely identifies subject
 - Subject's public key
 - Signature: encrypted hash

Validation and Cross-Certifying

- Alice's CA is Cathy; Bob's CA is Don; how can Alice validate Bob's certificate?
 - Have Cathy and Don cross-certify
 - Each issues certificate for the other
- Certificates:
 - Cathy<<Alice>>
 - Dan<<Bob>
 - Cathy<<Dan>>
 - Dan<<Cathy>>
- Alice validates Bob's certificate
 - Alice obtains Cathy<<Dan>>
 - Alice uses (known) public key of Cathy to validate Cathy<<Dan>>
 - Alice uses Cathy<<Dan>> to validate Dan<<Bob>>

PGP Chains

- OpenPGP certificates structured into packets
 - One public key packet
 - Zero or more signature packets
- Public key packet:
 - Version (3 or 4; 3 compatible with all versions of PGP, 4 not compatible with older versions of PGP)
 - Creation time
 - Validity period (not present in version 3)
 - Public key algorithm, associated parameters
 - Public key

OpenPGP Signature Packet

- Version 3 signature packet
 - Version (3)
 - Signature type (level of trust)
 - Creation time (when next fields hashed)
 - Signer's key identifier (identifies key to encrypt hash)
 - Public key algorithm (used to encrypt hash)
 - Hash algorithm
 - Part of signed hash (used for quick check)
 - Signature (encrypted hash)
- Version 4 packet more complex

Signing

- Single certificate may have multiple signatures
- Notion of “trust” embedded in each signature
 - Range from “untrusted” to “ultimate trust”
 - Signer defines meaning of trust level (no standards!)
- All version 4 keys signed by subject
 - Called “self-signing”

Validating Certificates

- Alice needs to validate Bob's OpenPGP cert
 - Does not know Fred, Giselle, or Ellen
- Alice gets Giselle's cert
 - Knows Henry slightly, but his signature is at "casual" level of trust
- Alice gets Ellen's cert
 - Knows Jack, so uses his cert to validate Ellen's, then hers to validate Bob's

Arrows show signatures
Self signatures not shown

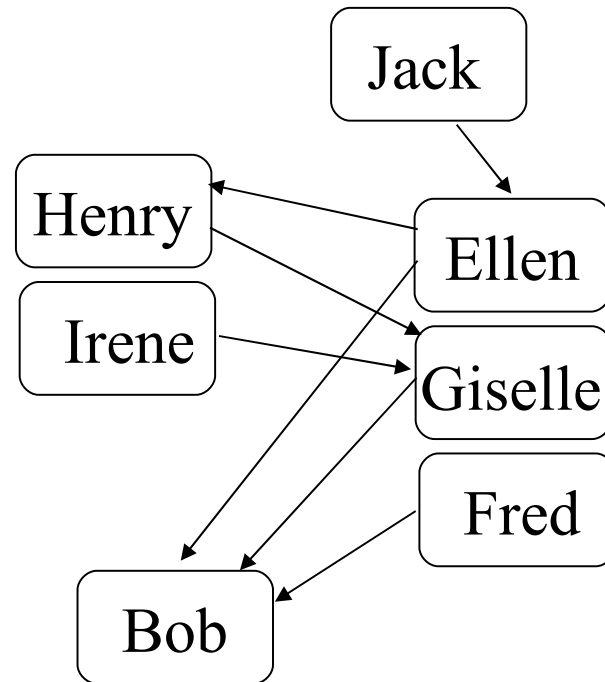

Key Revocation

- Certificates invalidated *before* expiration
 - Usually due to compromised key
 - May be due to change in circumstance (*e.g.*, someone leaving company)
- Problems
 - Verify that entity revoking certificate authorized to do so
 - Revocation information circulates to everyone fast enough
 - Network delays, infrastructure problems may delay information

CRLs

- *Certificate revocation list* lists certificates that are revoked
- X.509: only certificate issuer can revoke certificate
 - Added to CRL
- PGP: signers can revoke signatures; owners can revoke certificates, or allow others to do so
 - Revocation message placed in PGP packet and signed
 - Flag marks it as revocation message

Digital Signature

- Construct that authenticated origin, contents of message in a manner provable to a disinterested third party (“judge”)
- Sender cannot deny having sent message (service is “nonrepudiation”)
 - Limited to *technical* proofs
 - Inability to deny one’s cryptographic key was used to sign
 - One could claim the cryptographic key was stolen or compromised
 - Legal proofs, *etc.*, probably required; not dealt with here

Simple Approach

- Classical: Alice, Bob share key k
 - Alice sends $m \parallel \{ m \}_k$ to Bob

This is a digital signature

WRONG

This is not a digital signature

- Why? Third party cannot determine whether Alice or Bob generated message

Classical Digital Signatures

- Require trusted third party
 - Alice, Bob each share keys with trusted party Cathy
- To resolve dispute, judge gets $\{ m \} k_{Alice}$, $\{ m \} k_{Bob}$, and has Cathy decipher them; if messages matched, contract was signed

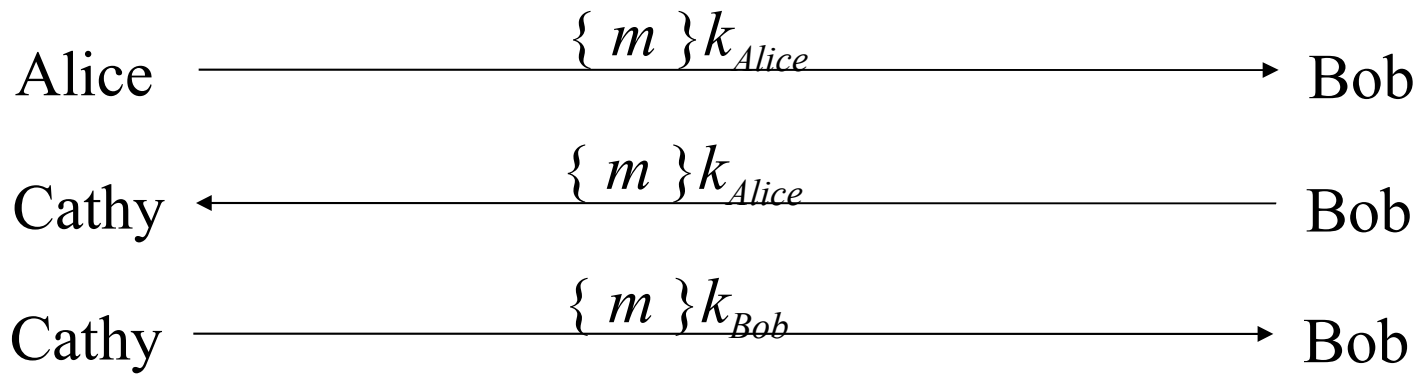

Public Key Digital Signatures

- Alice's keys are d_{Alice} , e_{Alice}

- Alice sends Bob

$$m \parallel \{ m \}_{d_{Alice}}$$

- In case of dispute, judge computes

$$\{ \{ m \}_{d_{Alice}} \}_{e_{Alice}}$$

- and if it is m , Alice signed message
 - She's the only one who knows d_{Alice} !

RSA Digital Signatures

- Use private key to encrypt message
 - Protocol for use is *critical*
- Key points:
 - Never sign random documents, and when signing, always sign hash and never document
 - Mathematical properties can be turned against signer
 - Sign message first, then encrypt
 - Changing public keys causes forgery

Attack #1

- $m_1 \times m_2 \bmod n_b = m$
- Get Bob to sign m_1 and m_2
- $m_1^d \bmod n_b \times m_2^d \bmod n_b =$
- $(m_1^d \times m_2^d) \bmod n_b =$
- $(m_1 \times m_2)^d \bmod n_b = m^d \bmod n_b$

Attack #1 example

- Example: Alice, Bob communicating
 - $n_A = 95, e_A = 59, d_A = 11$
 - $n_B = 77, e_B = 53, d_B = 17$
- 26 contracts, numbered 00 to 25
 - Alice has Bob sign 05 and 17:
 - $c = m^{d_B} \bmod n_B = 05^{17} \bmod 77 = 3$
 - $c = m^{d_B} \bmod n_B = 17^{17} \bmod 77 = 19$
 - Alice computes $05 \times 17 \bmod 77 = 08$; corresponding signature is $03 \times 19 \bmod 77 = 57$; claims Bob signed 08
 - Judge computes $c^{e_B} \bmod n_B = 57^{53} \bmod 77 = 08$
 - Signature validated; Bob is toast

Attack #2: Bob's Revenge

- Bob, Alice agree to sign contract m but wants it to appear that she signed contract M
 - Alice encrypts, then signs:
$$(m^{e_B} \bmod n_B)^{d_A} \bmod n_A$$
- Bob now changes his public key
 - Computes r such that $M^r \bmod n_B = m$
 - Replace public key e'_B with re_B and computes a new matching private key d'_B
- Bob claims contract was M . Judge computes:
 - $(c^{e_A} \bmod n_A)^{d'_B} \bmod n_B = M$

Attack #2 Example

- Bob, Alice agree to sign contract 06
- Alice encrypts, then signs:
$$(m^{e_B} \bmod 77)^{d_A} \bmod n_A = (06^{53} \bmod 77)^{11} \bmod 95 = 63$$
- Bob now changes his public key
 - Computes r such that $13^r \bmod 77 = 6$; say, $r = 59$
 - Computes $re_B \bmod \phi(n_B) = 59 \times 53 \bmod 60 = 7$
 - Replace public key e_B with 7, private key $d_B = 43$
- Bob claims contract was 13. Judge computes:
 - $(63^{59} \bmod 95)^{43} \bmod 77 = 13$
 - Verified; now Alice is toast

El Gamal Digital Signature

- Relies on discrete log problem
- Choose p prime, g , $d < p$; compute $y = g^d \bmod p$
- Public key: (y, g, p) ; private key: d
- To sign contract m :
 - Choose k relatively prime to $p-1$, and not yet used
 - Compute $a = g^k \bmod p$
 - Find b such that $m = (da + kb) \bmod p-1$
 - Signature is (a, b)
- To validate, check that
 - $y^a a^b \bmod p = g^m \bmod p$

Example

- Alice chooses $p = 29$, $g = 3$, $d = 6$
 $y = 3^6 \bmod 29 = 4$
- Alice wants to send Bob signed contract 23
 - Chooses $k = 5$ (relatively prime to 28)
 - This gives $a = g^k \bmod p = 3^5 \bmod 29 = 11$
 - Then solving $23 = (6 \times 11 + 5b) \bmod 28$ gives $b = 25$
 - Alice sends message 23 and signature (11, 25)
- Bob verifies signature: $g^m \bmod p = 3^{23} \bmod 29 = 8$
and $y^a a^b \bmod p = 4^{11} 11^{25} \bmod 29 = 8$
 - They match, so Alice signed

Attack

- Eve learns k , corresponding message m , and signature (a, b)
 - Extended Euclidean Algorithm gives d , the private key
- Example from above: Eve learned Alice signed last message with $k = 5$
$$m = (da + kb) \bmod p-1 = (11d + 5 \times 25) \bmod 28$$
so Alice's private key is $d = 6$

Storing Keys

- Multi-user or networked systems: attackers may defeat access control mechanisms
 - Encrypt file containing key
 - Attacker can monitor keystrokes to decrypt files
 - Key will be resident in memory that attacker may be able to read
 - Use physical devices like “smart card”
 - Key never enters system
 - Card can be stolen, so have 2 devices combine bits to make single key

Key Escrow

- *Key escrow system* allows authorized third party to recover key
 - Useful when keys belong to roles, such as system operator, rather than individuals
 - Business: recovery of backup keys
 - Law enforcement: recovery of keys that authorized parties require access to
- Goal: provide this without weakening cryptosystem
- Very controversial

Desirable Properties

- Escrow system should not depend on encryption algorithm
- Privacy protection mechanisms must work from end to end and be part of user interface
- Requirements must map to key exchange protocol
- System supporting key escrow must require all parties to authenticate themselves
- If message to be observable for limited time, key escrow system must ensure keys valid for that period of time only

Components

- User security component
 - Does the encryption, decryption
 - Supports the key escrow component
- Key escrow component
 - Manages storage, use of data recovery keys
- Data recovery component
 - Does key recovery

Example: ESS, Clipper Chip

- Escrow Encryption Standard
 - Set of interlocking components
 - Designed to balance need for law enforcement access to enciphered traffic with citizens' right to privacy
- Clipper chip given to users prepares per-message escrow information
 - Each chip numbered uniquely by UID
 - Special facility programs chip
- Key Escrow Decrypt Processor (KEDP)
 - Available to agencies authorized to read messages

Initialization of User Security Component

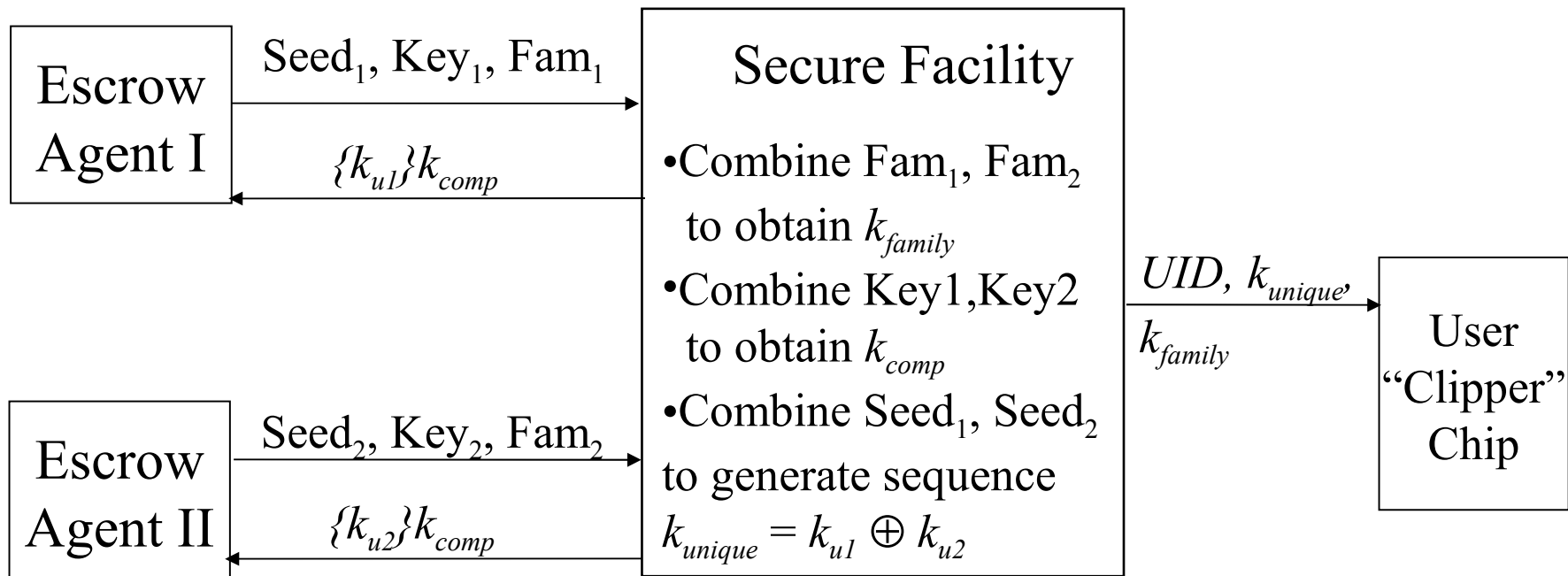

User Security Component

- Unique device key k_{unique}
- Non-unique family key k_{family}
- Cipher is Skipjack
 - Classical cipher: 80 bit key, 64 bit input, output blocks
- Generates Law Enforcement Access Field (LEAF) of 128 bits:
 - $\{ UID \parallel \{ k_{session} \} k_{unique} \parallel hash \} k_{family}$
 - *hash*: 16 bit authenticator from session key and initialization vector

Obtaining Access

- Alice obtains legal authorization to read message
- She runs message LEAF through KEDP
 - LEAF is $\{ \text{UID} \parallel \{ k_{\text{session}} \} k_{\text{unique}} \parallel \text{hash} \} k_{\text{family}}$
- KEDP uses (known) k_{family} to validate LEAF, obtain sending device's UID
- Authorization, LEAF taken to escrow agencies

Agencies' Role

- Each validates authorization
- Each supplies $\{ k_{ui} \} k_{comp}$, corresponding key number
- KEDP takes these and LEAF: $\{ \text{UID} \parallel \{ k_{session} \} k_{unique} \parallel hash \} k_{family}$
 - Key numbers produce k_{comp}
 - k_{comp} produces k_{u1} and k_{u2}
 - k_{u1} and k_{u2} produce k_{unique}
 - k_{unique} and LEAF produce $k_{session}$

Problems

- *hash* too short
 - LEAF 128 bits, so given a hash:
 - 2^{112} LEAFs show this as a valid hash
 - 1 has actual session key, UID
 - Takes about 42 minutes to generate a LEAF with a valid hash but meaningless session key and UID
 - Turns out deployed devices would prevent this attack
 - Scheme does not meet temporal requirement
 - As k_{unique} fixed for each unit, once message is read, any future messages can be read

Yaksha Security System

- Key escrow system meeting all 5 criteria
- Based on RSA, central server
 - Central server (Yaksha server) generates session key
- Each user has 2 private keys
 - Alice's modulus n_A , public key e_A
 - First private key d_{AA} known only to Alice
 - Second private key d_{AY} known only to Yaksha central server
 - $d_{AA} d_{AY} = d_A \text{ mod } \Phi(n_A)$

Alice and Bob

- Alice wants to send message to Bob
 - Alice asks Yaksha server for session key
 - Yaksha server generates $k_{session}$
 - Yaksha server sends Alice the key as:
$$C_A = (k_{session})^{d_{AyeA}} \bmod n_A$$
 - Alice computes
$$(C_A)^{d_{AA}} \bmod n_A = k_{session}$$

Analysis

- Authority can read only one message per escrowed key
 - Meets requirement 5 (temporal one), because “time” interpreted as “session”
- Independent of message enciphering key
 - Meets requirement 1
 - Interchange algorithm, keys fixed
- Others met by supporting infrastructure

Alternate Approaches

- Tie to time
 - Session key not given as escrow key, but related key is
 - To derive session key, must solve instance of discrete log problem
- Tie to probability
 - Oblivious transfer: message received with specified probability
 - Idea: *translucent cryptography* allows fraction f of messages to be read by third party
 - Not key escrow, but similar in spirit

Key Points

- Key management critical to effective use of cryptosystems
 - Different levels of keys (session *vs.* interchange)
- Exchange algorithms can be vulnerable to attacks
 - Replay
 - Identity integrity
- Digital signatures provide integrity of origin and content
 - Much easier with public key cryptosystems than with classical cryptosystems
- Keys need infrastructure to identify holders, allow revoking and possible escrow